

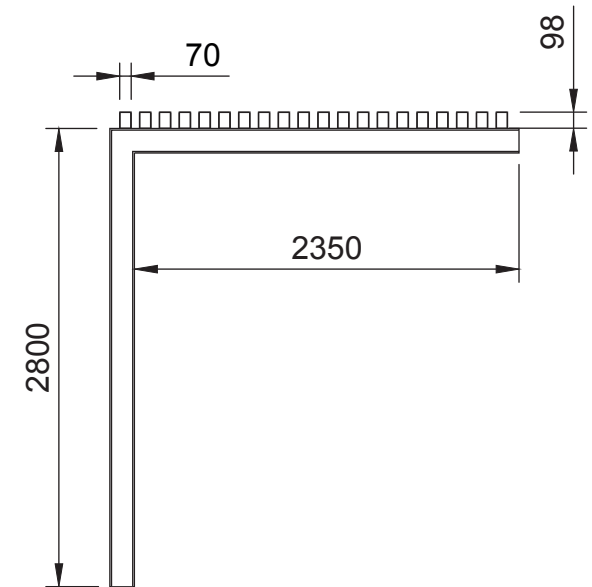

"Goren" Shading system

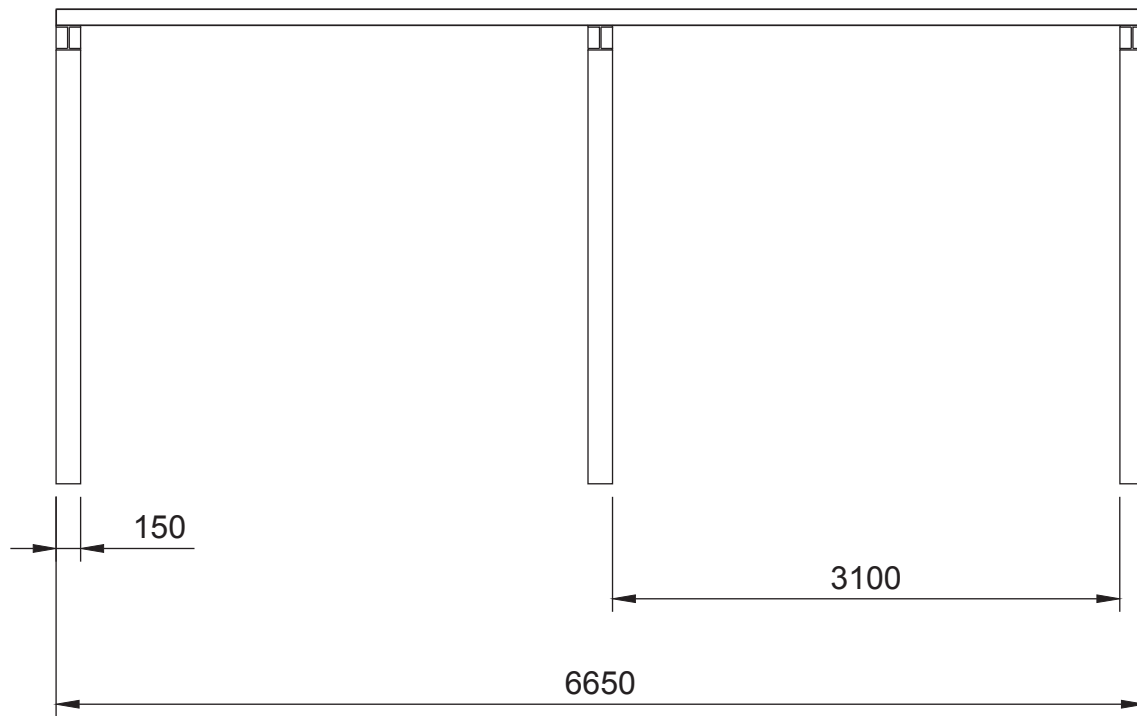



"Goren" Shading system

